



Model BKA Installation Instructions

**WARNING: ALARMS WILL NOT PROPERLY SOUND IF THE GONG IS OBSTRUCTED.
BE SURE TO CHECK FOR THE FOLLOWING:**

- Keep internal and external mechanisms clear of all dirt, snow, materials, etc., which may interfere with its proper operation.
- Keep hammer and spring in adjustment to ensure proper striking.

Installation Notes:

- As received, your Model BKA (Backup Alarm) will sound **BACKING UP** when mounted on the **LEFT** side of the vehicle (see Fig. 1). If you require operation in another mode, choose from the arrangements shown in Figs. 2 or 3. Be sure to place the hammers & stops as illustrated
- Due to the different bolt diameters and lengths used we do not furnish mounting hardware. These are generally available in maintenance shops where the units are installed.
- The Model BKA will accommodate wheel lug bolt patterns using 2 opposite wheel lugs with bolt circles from 2-1/4 to 5-3/4 inches.

Installation, alignment, final assembly and test

- Remove the Model BKA gong shell.
- Remove 2 opposite wheel lug nuts.
- Position the alarm plate of the Model BKA alarm so it is visually centered on the wheel hub
- Loosely secure the Model BKA to the wheel hub with the lug nuts.
- Confirm alignment by rotating the wheel of the vehicle. Minimize runout (wobble) for proper operation.
- Fully tighten all nuts and screws.
- Replace the gong shell and gong shell nut. Tighten fully.
- Confirm proper operation of the Model BKA before placing the vehicle in service. (See adjustments, below)
- Periodically confirm proper operation of the Model BKA on the vehicle.
- Keep gong shell free of mud and other material or objects that may affect or mute the sound.

ADJUSTMENTS Leaf springs are used to allow the hammer to strike the gong and then rebound for a clear ringing sound, and have been pre-adjusted at the factory. However disassembly or prolonged use may make readjustment necessary.

Clanking noises (not a clear ringing gong sound) come from a hammer resting on the gong after striking. The leaf spring is too far toward the gong shell. Use long bent-nosed pliers to gently bend the spring back toward the center. Over adjustment will result in failure to ring. (See Figure 4).

No ringing is caused when the hammer coming to rest short of gong. The leaf spring is bent too far toward the center. Use long bent-nosed pliers to gently bend the spring away from the center. Over adjustment will result in the clanking sound referred to above.

Fig. 1

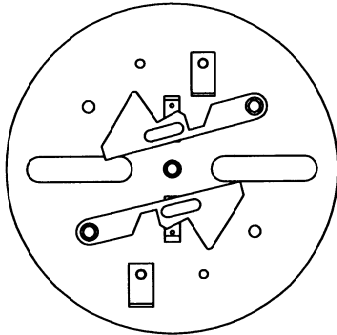

MODEL BKA FACTORY EQUIPPED IN THIS CONFIGURATION

- Sounds ONLY in REVERSE motion when mounted on the LEFT side of the vehicle.
- Sounds ONLY in FORWARD motion when mounted on the RIGHT side of the vehicle.
- TWO rings per wheel revolution.

Fig. 2

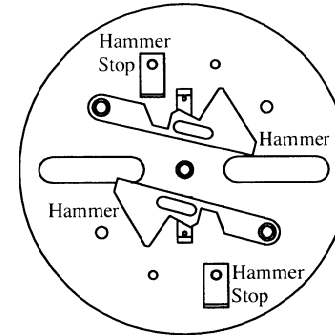

REINSTALL BOTH HAMMER AND HAMMER STOPS LIKE THIS FOR:

- Sounds ONLY in FORWARD motion when mounted on the LEFT side of the vehicle.
- Sounds ONLY in REVERSE motion when mounted on the RIGHT side of the vehicle
- TWO Rings per wheel revolution

Fig. 3

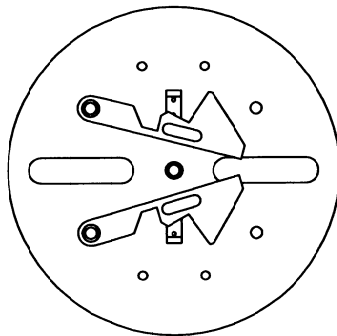

REINSTALL ONE HAMMER AND REMOVE BOTH HAMMER STOPS LIKE THIS:

- Sounds in BOTH FORWARD and in REVERSE motion when mounted on EITHER side of the vehicle
- ONE Ring per wheel revolution

Fig. 4 Hammer Stop Assembly

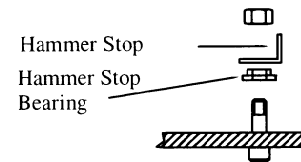

Fig. 5 Hammer Assembly

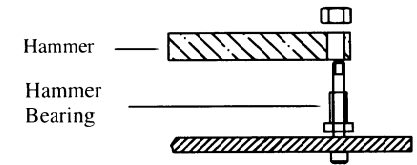

Fig. 6 Hammer Spring Adjustment

